

Customer Information Sheet

DRAWING No.: Z125-900

SHEET 2 OF 2

IF IN DOUBT - ASK

©

NOT TO SCALE

THIRD ANGLE PROJECTION

ALL DIMENSIONS IN mm

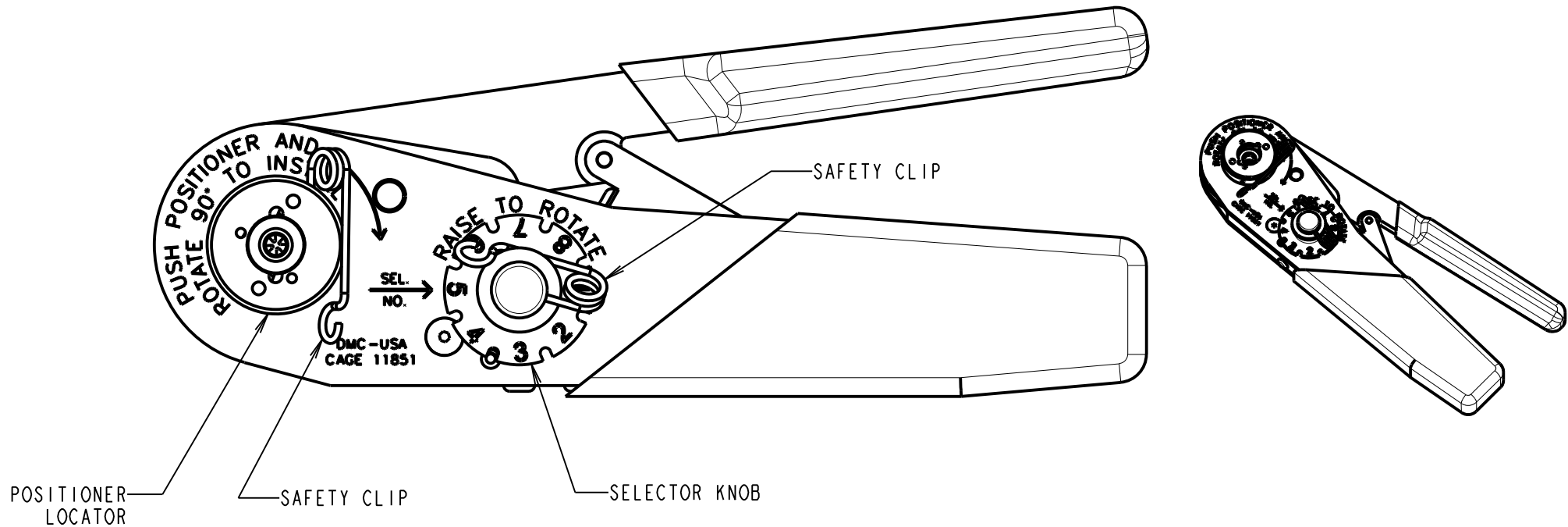

NOTES:

- HAND CRIMP TOOL MUST BE USED WITH POSITIONER AND SELECTOR NUMBER SETTING AS SHOWN IN TABLE.
- SEE INSTRUCTION SHEET IS-37 FOR INSTRUCTIONS.

POSITIONER	CONTACT PART No.	SELECTOR NUMBER	WIRE SIZE
Z125-901	G125-00100XX	6	26 AWG
	G125-00200XX	5	28, 30, 32 AWG
	G125-10100XX	6	26 AWG
	G125-10200XX	5	28, 30, 32 AWG

MGP	2	10.07.12	11771
NAME	ISS.	DATE	C/NOTE
APPROVED: MGP			
CHECKED: SF			
DRAWN:		S.BENNETT	
CUSTOMER REF.:			
ASSEMBLY DRG:			

HARWIN

www.harwin.com
technical@harwin.com

THIS DRAWING AND ANY INFORMATION OR DESCRIPTIVE MATTER SET OUT HEREON ARE CONFIDENTIAL AND COPYRIGHT PROPERTY OF THE HARWIN GROUP AND MUST NOT BE DISCLOSED, LOANED, COPIED OR USED FOR MANUFACTURING, TENDERING OR FOR ANY OTHER PURPOSE WITHOUT THEIR WRITTEN PERMISSION.

TOLERANCES
 X. = ±1mm
 X.X = ±0.25mm
 X.XX = ±0.10mm
 X.XXX = ±0.01mm
ANGLES = ±5°
 UNLESS STATED

MATERIAL:

FINISH:

S/AREA:

mm²

TITLE: G125 GECKO CONTACT
HAND CRIMP TOOL

DRAWING NUMBER:

Z125-900

SHT
2
OF
2